

In series

The model is in series and available for the long term.



Specification

Sensor

Sensor type	CMOS Mono
Shutter	Global Shutter
Sensor characteristic	Linear
Readout mode	Progressive scan
Pixel Class	5 MP
Resolution	5.01 Mpix
Resolution (h x v)	2448 x 2048 Pixel
Aspect ratio	5:4
ADC	12 bit
Color depth (camera)	12 bit
Optical sensor class	2/3"
Optical Size	8.446 mm x 7.066 mm)
Optical sensor diagonal	11.01 mm (1/1.45")
Pixel size	3.45 µm
Manufacturer	Sony
Sensor Model	IMX264LLR-C
Gain (master/RGB)	24x/4x
AOI horizontal	same frame rate
AOI vertical	increased frame rate
AOI image width / step width	256 / 8
AOI image height / step width	1 / 1
AOI position grid (horizontal/vertical)	8 / 1
Binning horizontal	same frame rate
Binning vertical	increased frame rate
Binning method	M/C automatic
Binning factor	2 / 4 / 8
Subsampling horizontal	same frame rate
Subsampling vertical	same frame rate
Subsampling method	M/C automatic
Subsampling factor	2, 4, 8

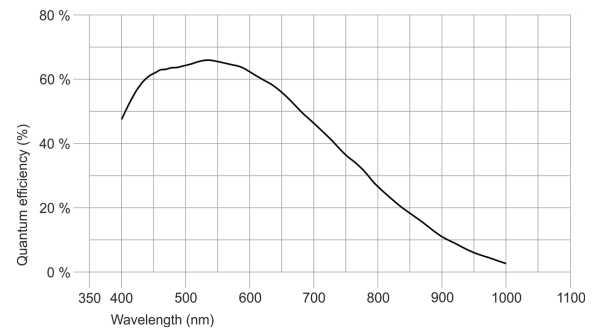

Model

Frame rate freerun mode (in 8-bit mode)	36 fps
Frame rate trigger (continuous)	36 fps
Frame rate trigger (maximum)	37 fps
Exposure time (minimum - maximum)	0.027 ms - 2000 ms
Long exposure (maximum)	90000 ms
Power consumption	1.6 W - 3.1 W
Image memory	128 MB

Ambient conditions

The temperature values given below refer to the outer device temperature of the camera housing.

Device temperature during operation	0 °C - 55 °C / 32 °F - 131 °F
Device temperature during storage	-20 °C - 60 °C / -4 °F - 140 °F
Humidity (relative, non-condensing)	20 % - 80 %

Connectors

Interface connector	USB 3.0 micro-B, screwable
I/O connector	8-pin Hirose connector (HR25-7TR-8PA(73))
Power supply	USB cable

Pin assignment I/O connector

1	Ground (GND)
2	Flash output with optocoupler (-) - Line 1
3	General Purpose I/O (GPIO) 1 - Line 2
4	Trigger input with optocoupler (-) - Line 0
5	Flash output with optocoupler (+) - Line 1
6	General Purpose I/O (GPIO) 2
7	Trigger input with optocoupler (+) - Line 0
8	Output supply voltage, 5 V (100 mA)



Design

Lens Mount	C-Mount
IP code	IP30
Dimensions H/W/L	29.0 mm x 29.0 mm x 29.0 mm
Mass	50 g

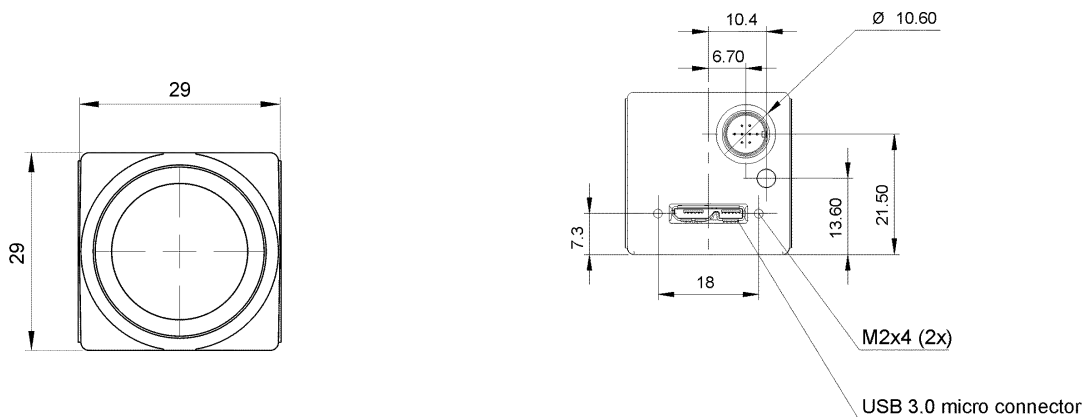

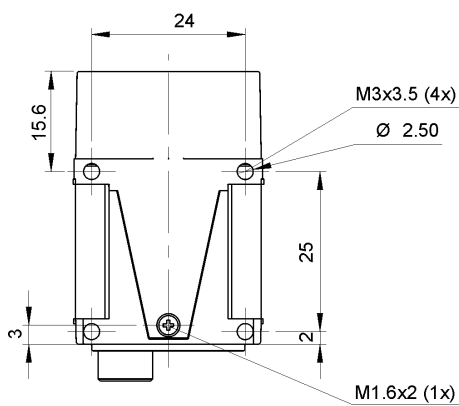
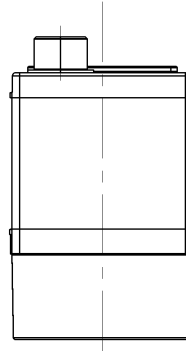
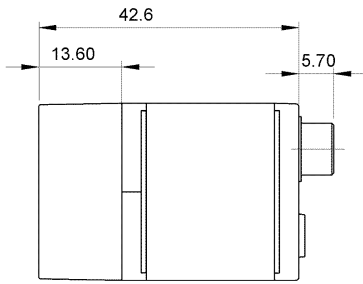

Features

Image Acquisition

Freerun	✓
Software trigger	✓
Hardware trigger	✓
Trigger controlled exposure	✓
Denoisier	✓
Long exposure	✓
Line scan	✓
Line scan highspeed	-

Flashing

Flashing	✓
PWM flashing	✓

Image Adjustments

Auto exposure	✓
Auto gain	✓
Auto whitebalance	-
Color correction	-
Gamma	✓
LUT	✓
Mirror/flip	X/Y

On-board Image Processing

Pixel formats	Mono8 Mono10 Mono10p Mono12 Mono12p
Region of interest	✓
Decimation (FPGA)	✓
Decimation (Sensor)	-
Binning (FPGA)	✓
Binning (Sensor)	1x2 Increases frame rate.

Others

Chunks	✓
Sequencer	✓
Events	✓
Firmware update	✓
1st supported firmware version	2.20



VISION CONSULTANCY
MAKING THE UNSEEN VISIBLE

Thank you for downloading this document from
www.machine-vision-shop.com

If you have any questions, you need help composing the
right package for your application or do you want to order?

Feel free to contact us via e-mail at sales@vision-consultancy.nl or visit our webshop.

Our vision experts are happy to help you.



Natascha Overhof



Christian Cromptvoets



VISION CONSULTANCY

Robert Schumandomein 2
6229 ES Maastricht
The Netherlands

+31 (0) 438 522 651

sales@vision-consultancy.nl
www.machine-vision-shop.com

Scan me to visit
[machine-vision-shop](http://machine-vision-shop.com)

