

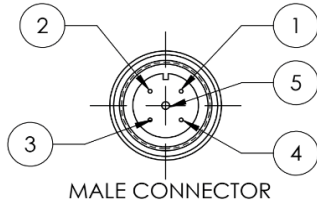

ILLUMINATOR DATA-ID

BHP1010-X-B-24V

Lighting Dimension



PIN	CORD COLOR	DESCRIPTION
1	BROWN	24V
2	WHITE	-
3	BLUE	GND
4	BLACK	-
5	GRAY	-

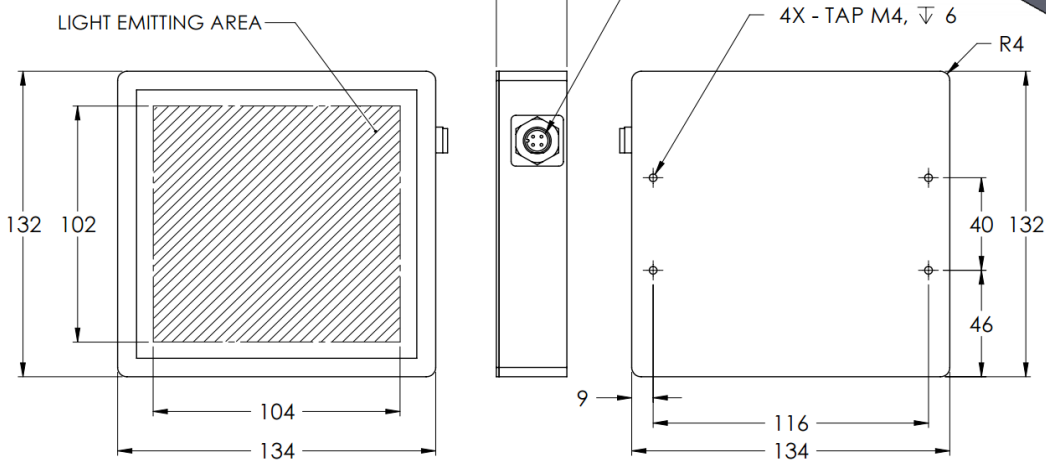
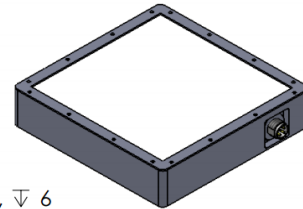

Mechanical Information	
Casing Material	Aluminium
Storage Temperature Range	Temp 0 - 45°C, Humidity 20-85%
Weight	650 g
Length / Outer Diameter	132 mm
Width / Inner Diameter	134 mm
Thickness / Height	30 mm



ILLUMINATOR DATA-ID

BHP1010-X-B-24V

Optical Information			
Part Number	BHP1010-X-B-24V		
LED Color	BLUE		
Wavelength (nm)	470		
Intensity (±15%) (Lux)	34500	29600	25100
Working Distance (mm)	10	20	30
Illumination (number of row)	X		
Illumination Active Area			
Active Length / Outer Diameter (mm)	102		
Active Width / Inner Diameter (mm)	104		
Emission angle (deg.)	0		
Eye Safety Class (IEC62471)	II		
Electrical Information			
Lighting Supply Voltage (constant voltage mode)	24V ± 2%		
Continuous Current (mA)	285		
Power Consumption (W)	6.84		
Lighting casing temperature, Operating after 60 minutes (°C)	44.8		
Strobe Mode Specification			
Pulse Operation	YES		
Max. Lighting Supply Voltage (Constant voltage power supply) (V)	Pulsing at 24VDC to 48VDC, 0-10% Duty Cycle, Recommended at 36VDC		
Pulse Current, (Max. 10msec) (Constant current power supply) (mA)	855		
Max. Trigger Pulse Duration (msec)	10		
Duty Cycle	0-10%		
Additional Information			
Additional Cooling Method	Attached to machine part for better heat dissipation		
Intensity Controller Selection	ANG, ST, SD and SDA Series		
CE Conformity	YES		
RoHS Compliance	YES		
Connection			
Connector Type (default)	M12 5 PIN CONNECTOR (MALE)		
Cable Length (out from lighting) (mm)	700		
Pin Configuration	Pin	Signal	Cable Colour
	1	24V	BROWN
	2	-	WHITE
	3	GND	BLUE
	4	-	BLACK
	5	-	GRAY
Extension Cable			
Connector Type (default)	M12 5 PIN CONNECTOR (FEMALE)		
Part Number	EXT-FL-M12F-3M-24V		
Cable Length (out from female connector) (mm)	3000		
Extension Cable (connect to M12 5 Pin Male Connector from lighting)			
Application			
Illumination Type	Ingress Protection Illumination		
Applicattion Use	Lead frame inspection, shape recognition, size measurement.		



VISION CONSULTANCY
MAKING THE UNSEEN VISIBLE

Thank you for downloading this document from
www.machine-vision-shop.com

If you have any questions, you need help composing the
right package for your application or do you want to order?

Feel free to contact us via e-mail at sales@vision-consultancy.nl or visit our webshop.

Our vision experts are happy to help you.



Natascha Overhof



Christian Cromptvoets



VISION CONSULTANCY

Robert Schumandomein 2
6229 ES Maastricht
The Netherlands

+31 (0) 438 522 651

sales@vision-consultancy.nl
www.machine-vision-shop.com

Scan me to visit
[machine-vision-shop](http://machine-vision-shop.com)

